Eisner Safety Consultants is Proud to Present a Series on IEC 60601-1

EST 101 (Fifth in a Series of Articles)

So far we have discussed the IEC 60601-1 Medical Electrical Equipment standard, reasons why manufacturers should safety test their electronic medical products and how IEC60601-1 classifies products for specific tests. Now let's shed a little light on what exactly electrical safety testing (EST) is and how the various tests are performed. Electrical Safety Testing verifies product safety under simulated fault and/or material stress conditions. The goal is to test the product to its limitations to make sure that it can withstand the electrical conditions it will be subjected to on the job - not just the specifications it is built to but also the environment in which it is potentially used.



Electrical Safety Tests

Electrical Safety Testing in IEC 60601-1 includes Dielectric Strength, Leakage Current and Protection Earth Verification type tests. The type or compliance test differs from a production test because it is not performed on every production unit. The dielectric strength test may be referred to as dielectric withstand, dielectric breakdown or hipot (high potential) but the procedure is the same: using a high voltage, stress the insulation beyond what it would encounter in normal (specified) use. Leakage current tests detect the amount of leakage present to a patient or operator when the medical device is energized and if that amount is at a safe level. The most important safety test is verifying the product's protective earth connection. This is performed using a ground continuity or ground bond test. Although not required by IEC 60601-1, an insulation resistance test measures the strength of insulation within a product and it is a very common electrical safety production test.

The basic electrical safety tests are:

Protective Earth Verification:	Ground Continuity Test Ground Bond Test
Dielectric Strength:	AC Hipot Test DC Hipot Test
High Resistance:	Insulation Resistance Test
Leakage Current:	Earth Leakage, Touch/Chassis (Enclosure), Patient Leakage & Patient Auxiliary Leakage

This application note contains an example of each test and definitions of common EST terms. IEC60601-1 is primarily focused on type testing of products. Production tests or routine tests performed on every product are not always identical to type tests and may be adapted to specific manufacturing conditions. If your product is tested by a third party test agency or NRTL, they may require specific tests be performed.

Protective Earth Verification

The two tests for verification of ground connection (protective earth) are Ground Continuity and Ground Bond. Common sense, not mandates from standards, should render these tests necessary but we take for granted that a person who walks up and touches an electrical product does not get shocked.



A ground continuity (GC) test checks that there is a connection between exposed conductive parts and the ground of the power cord being tested. A low current signal, typically less than 1 Amp is applied to the device under test.

A Ground Bond test determines the strength of that ground connection with a high current signal, typically 25Amps. IEC60601-1 specifies that user-accessible conductive parts connected to the safety ground be tested with a current of either 25A or 1.5 times the product's current consumption, whichever is greater. The current must source from a maximum no-load voltage of 6V AC. The test is performed for 5 to 10 seconds. The resistance of this ground path equals test current divided by voltage drop. Ohms Law: $V=RI$, solving for R, $R = V/I = 6V/25A = 0.24\Omega$. IEC60601-1 specifies that the resistance be $<0.1\Omega$ on equipment with a detachable power cord and $<0.2\Omega$ for equipment with a permanently attached power cord.

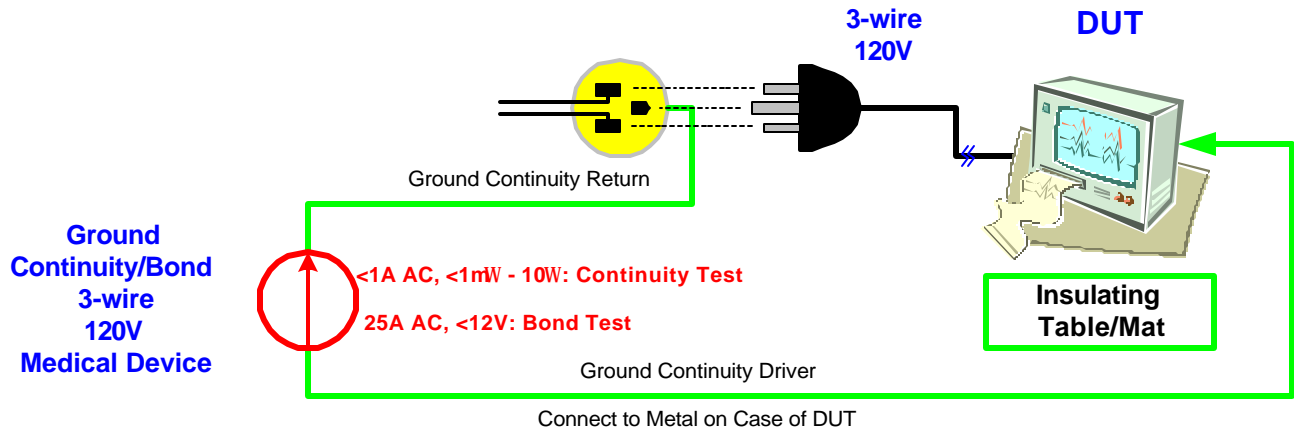

Figure 1.0a: Ground Continuity/Bond Test

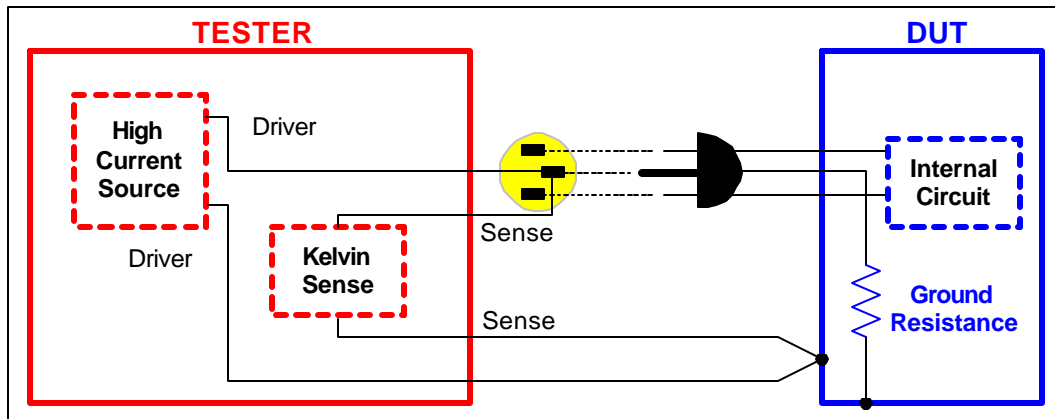

Figure 1.0b: Ground Bond Test employing 4-terminal Kelvin connection

Dielectric Strength

An AC hipot, DC hipot or both are required product safety tests for electrical medical devices. Whether to perform an AC or a DC test is usually determined by answering the question: what powers this device? If the medical device is AC-powered (plugged into wall), then perform an AC hipot test. If the medical device is DC-powered (battery), then perform a DC hipot test. Figure 2.0 illustrates the connection diagram for an AC or DC line voltage test. The IEC60601-1 standard and its supporting standards specify the voltage to be applied to the device under test (DUT) and the acceptance criteria, usually: ‘no breakdown or repeated flashover shall occur’. For example: The supporting standard UL2601-1 in the product category of medical equipment, specifies the dielectric withstand test as: the test voltage = 1250V AC for 120V mains (1500V AC for 220V mains) or 2121V DC; the maximum current = ‘no arcover or breakdown’; and the test time = 60 seconds.

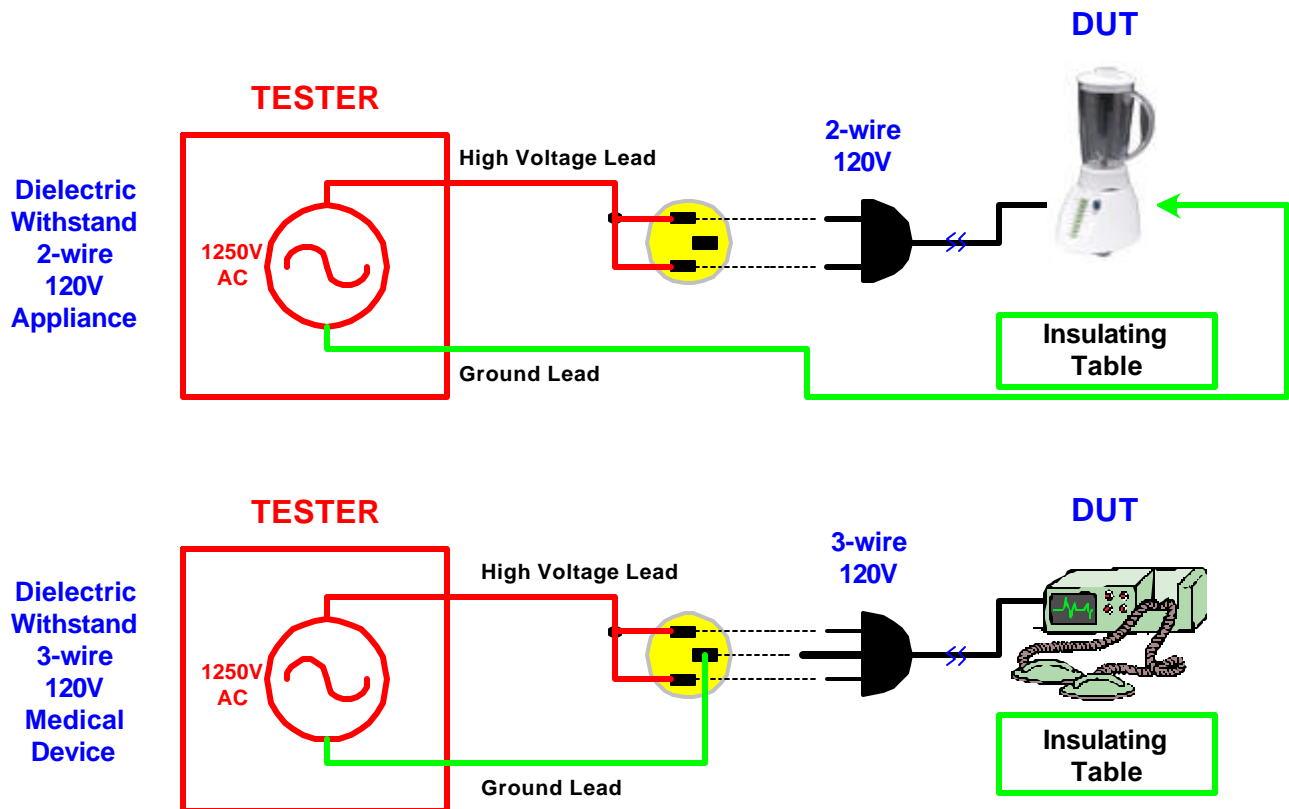

Figure 2.0: AC or DC Line Voltage Test

High Resistance

An Insulation Resistance (IR) test measures the total resistance between any two points separated by electrical insulation. The purpose is to determine the strength of the dielectric material (insulation) by stressing it with a high voltage. Voltage (typically 50-1000V DC) is applied to the device under test (DUT) and current is measured. That current flow is made up of three components: dielectric absorption, charging current and leakage current. Dielectric absorption is the physical occurrence of a device absorbing (retaining) charge like an electrolytic capacitor. Charging current represents itself in the insulation of a device as an instantaneous rise with the applied voltage, then quickly decays to zero. Leakage current is the component flowing through the insulation after the initial charge of the device. Leakage current is equal to the applied voltage divided by the insulation resistance of the device under test. Remember this residual leakage current from a HIGH voltage test is different than that measured under NORMAL operating conditions.

The DUT is configured in a grounded or ungrounded connection according to the type of device being tested. A two-terminal discrete device like a resistor or capacitor would be connected in a 2-wire ungrounded configuration. A two-terminal grounded device such as a cable submersed in a water bath would be connected in a 2-wire grounded configuration. Voltage is applied to the DUT, first it is charged to the programmed test level, then it may dwell for a period of time to stabilize this test voltage, the instrument then measures the resistance and in the last phase the voltage is discharged to zero.

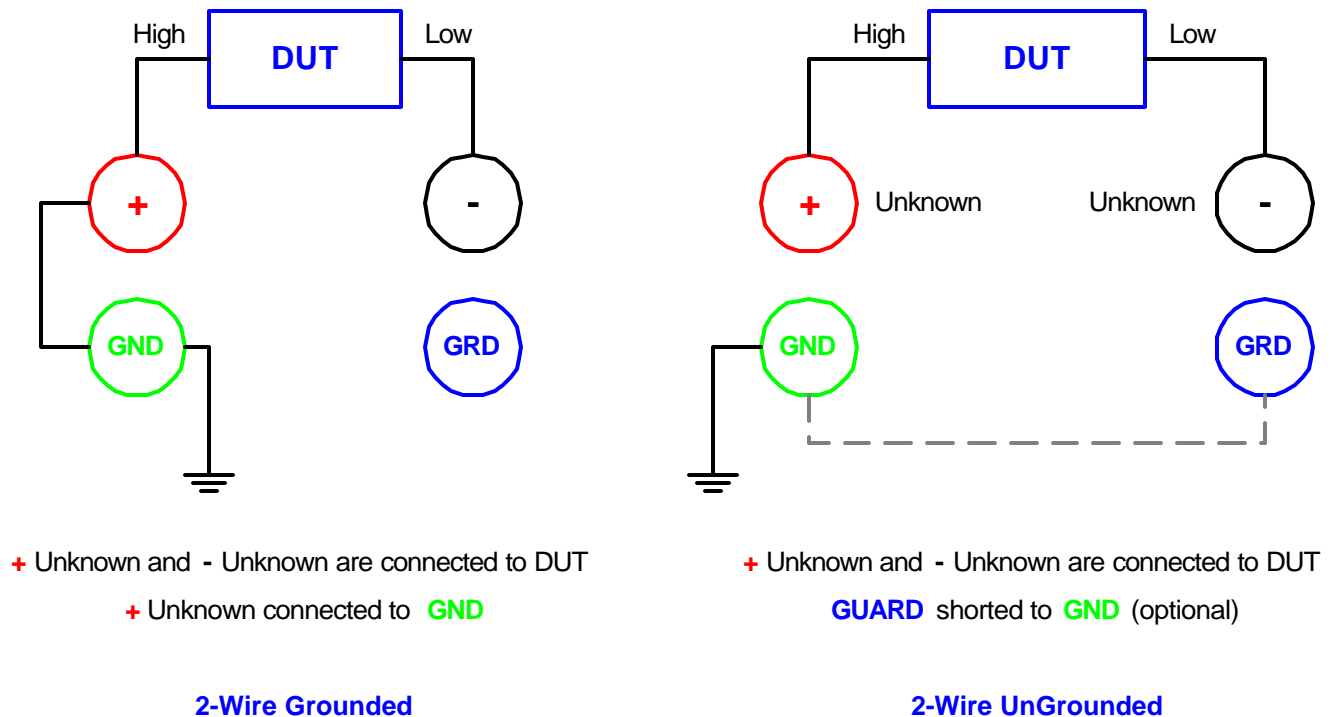

Figure 3.0: Insulation Resistance Test

Leakage Current

There are several current tests that can be specified by product safety standards. The most common is the Line (Earth) Leakage Current test. Medical standards require multiple current tests including Earth Leakage, Patient Leakage and Touch/Chassis (Enclosure) Leakage. All possibilities of the patient or operator coming into contact with leakage current and possible electrical shock are tested.

Leakage current definitions can be tricky since manufacturers use different words to explain the same conditions. Leakage current is the residual flow of current after HIGH voltage (greater than normal operating voltage) has been applied to the device under test (DUT). This is the current measured in a hipot test.

Line leakage current is that measured at 110% of highest rated operating voltage and highest rated frequency. The device under test is turned on and the line leakage is measured across a circuit that simulates the impedance of the human body. There are four types of leakage current: Earth, Touch/Chassis (Enclosure), Patient (Applied Part) and Patient Auxiliary.

Earth leakage is that line leakage current measured when the ground connector is open, a circuit that simulates the impedance of the human body is inserted and the voltage is measured across it.

Touch/Chassis (Enclosure) leakage is that line leakage current measured by connecting the circuit that simulates the impedance of the human body to any exposed part of the chassis of the DUT. This simulates someone touching the enclosure/chassis of the DUT.

Patient (Applied Part) leakage is that line leakage measured from or between applied parts of the DUT such as the current that might flow from patient leads and sensors on a medical device.

Patient Auxiliary leakage is that line leakage current flowing in the patient in NORMAL use between applied parts of the DUT and not intended to produce a physiological effect.

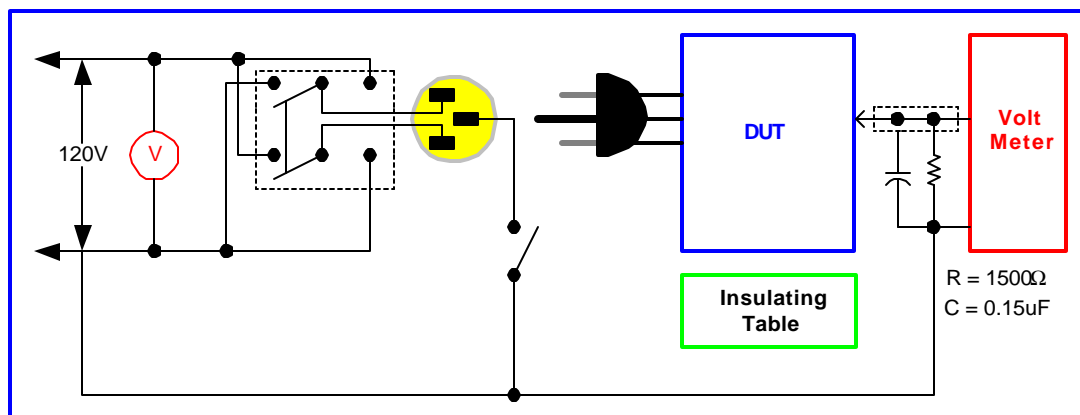

Figure 4.0: Line Voltage Leakage Current Test

NOTE:

Article #6 in this IEC 60601-1 Series will discuss leakage current in greater detail.

Definitions

AC:	Alternating Current, an electric current that has one polarity during one part of the cycle and the opposing polarity during the other part of the cycle. Residential electricity is AC.
Breakdown:	Failure of electrical insulation to provide a dielectric barrier to current flow.
Charging Current:	An insulated product exhibits the basic characteristics of a capacitor. Application of a voltage across the insulation causes a current to flow as the capacitor charges. This current instantaneously rises to a high value as voltage is applied then exponentially decays to zero as the DUT becomes fully charged. Charging current decays to zero much faster than dielectric absorption.
DC:	Direct Current, non-reversing polarity. The movement of charge is in one direction. Used to describe both current and voltage. Batteries supply direct current.
Dielectric Absorption:	The physical phenomenon in which insulation appears to absorb and retain an electrical charge slowly over time. Apply a voltage to a capacitor for an extended period of time and then quickly discharge it to zero voltage. Leave the capacitor open circuited for a period of time then connect a voltmeter to it and measure the residual voltage. The residual voltage is caused by the dielectric absorption of the capacitor.
Dielectric Strength	The Dielectric Strength of a material is the ratio between the voltage at which breakdown of the insulating material occurs and the distance between the two points subject to the applied voltage.
Dielectric Withstand Test	This is the most common electrical safety test performed today. A high voltage either AC or DC is applied to determine if a breakdown will occur in the insulation of the DUT. Also referred to as a HIPOT test or Dielectric Withstand test.
DUT	Device Under Test — the product being tested.
Earth Continuity Test	A test to verify that all conductive parts of a product that are exposed to user contact are connected to the power line ground. The ground bond test is similar to the ground continuity test. The main difference is that the ground bond test verifies the integrity of the ground connection using a high current AC signal with current level as high as 30Amps. Ground bond provides a better simulation of how a product will perform under an actual fault condition.
Ground	Ground is the base reference from which voltages are measured. It is nominally the same potential as the earth. Ground is also the side of a circuit that is at the same potential as the base reference.
Ground Bond Test	A test to verify that all conductive parts of a product that are exposed to user contact are connected to the power line ground. The ground bond test is similar to the ground continuity test. The main difference is that the ground bond test verifies the integrity of the ground connection using a high current AC signal with current level as high as 30Amps. Ground bond provides a better simulation of how a product will perform under an actual fault condition.
Ground Continuity Test	A test to verify that all conductive parts of a product that are exposed to user contact are connected to the power line ground. GC Test normally performed with a low current DC signal that checks to ensure the ground connection has a resistance of $<1 \Omega$.

Definitions

Insulation	The protection against unwanted flow of current through a path, as between a circuit of a product and the ground reference. Materials that prevent current flow are referred to as insulators or dielectrics.
Insulation Resistance	Characteristic of an insulating material that being subject to voltage, indicates a resistance such that the value of leakage current which flows through it stays within acceptable limits.
Leakage Current	The residual flow of current through insulation after a high voltage has been applied for a period of time.
Earth Leakage:	The most important and most common of the line leakage current tests, earth leakage current is basically the current flowing back through the ground conductor on the power cord. It is measured by opening the ground conductor, inserting a circuit with simulated the impedance of the human body and measuring the voltage across part of the circuit with a true RMS voltmeter.
Patient Leakage:	A line leakage current test that measures the current that would flow from or to applied parts and between applied parts such as sensor and patient leads.
Patient Auxiliary Leakage:	That line leakage current flowing in the patient in NORMAL use between applied parts of the DUT and not intended to produce a physiological effect.
Touch/Chassis Leakage:	A line leakage current test simulates the effect of a person touching exposed metal parts of a product and detects whether or not the leakage current that flows through the person's body remains below a safe level. Line leakage tests are conducted by applying power to the product being tested, then measuring the leakage current from any exposed metal on the chassis of the product under various fault conditions (such as "No Ground"). A special circuit is used to simulate the impedance of the human body.
Mode	Mode is the test that is to be performed such as AC Hipot (WAC), DC Hipot (WDC), Insulation Resistance (IR), Ground Bond (GR) or Leakage Current (LC).
Ohm's Law	Ohm's Law is the fundamental physical law of electrical circuits that describes the relations between voltage, current, and impedance (or resistance). For DC circuits, Ohm's Law states that $\text{Current} = \text{Voltage} / \text{Resistance}$. For AC circuits, $\text{Current} = \text{Voltage} / \text{Impedance}$. Stated conversely, $\text{Voltage} = \text{Current} \times \text{Resistance}$ (DC) or $\text{Current} \times \text{Impedance}$ (AC). The difference between the DC resistance and AC impedance is that AC circuits must deal with phase and time relationships and DC circuits do not.
Ohms	An ohm is the unit of measure of resistance and impedance, derived from Ohm's Law.
Polarization	A term used to describe a "one way" limitation on the insertion of a plug into a receptacle for a corded product. A polarized plug can be inserted in only one orientation and cannot be reversed.
Potential	Electrical potential is a term equivalent to "voltage".
Resistance	Resistance is the electrical characteristic that impedes the flow of current through a circuit to which voltage has been applied. Ohm's Law calculates $\text{Resistance} = \text{Voltage} / \text{Current}$ (for DC circuits). For AC circuits, it is the in-phase or "real" component of impedance. The unit of resistance is the ohm (Ω).
Voltage	The electrical potential applied to a circuit.

What does an Electrical Safety Tester Look Like?

Figure 6.0 illustrates the QuadTech Guardian 6000 Series Production Safety Analyzer. Five instruments in one, the Guardian 6000 has the capability to perform AC hipot, DC hipot, Insulation Resistance, Leakage Current and Ground Bond measurements from a single test connection. Standard IEEE-488 and Remote Control interfaces plus optional RS-232 or Printer interfaces make this instrument ideal for data storage, retrieval, transfer, analysis and communication. Rear panel 8-channel permits multiple-point testing decreasing test time and increasing throughput. The 6100 model is now available with the 6000-05 Leakage Current Scanner & Probe allowing eight possible configurations of a line/earth leakage current test. These include: normal operating conditions, reversed line, or a single fault normal and single fault reverse mode with the ground set on or off. Five different human body impedance circuits can be selected to model UL544NP, UL544P, UL1563, UL2601-1, IEC601-1, IEC950, UL1950 and UL3101 requirements.



Figure 5.0: Guardian 6000 Series

For complete product specifications on the 6000 Series Production Safety Analyzers or any of QuadTech's products, visit us at <http://www.quadtech.com/products>. Do you have an application specific testing need? Call us at 1-800-253-1230 or email engineering at rroetzer@quadtech.com and we'll work with you on a custom solution. Put QuadTech to the test because we're committed to solving your testing requirements.



For more information on product safety testing to IEC60601-1, contact Eisner Safety Consultants at (503) 244-6151, visit us on the web at <http://www.eisnersafety.com> or email us at Leo@EisnerSafety.com. Eisner Safety Consultants specializes in assisting clients with obtaining the European CE Mark and meeting US and Canadian regulatory standards. Specialties include product evaluation to safety standards, Agency coordination, CE Mark, Quality Systems and training.

DISCLAIMER

The organizations listed in this application note do **not** have any formal relationship, agreement or representation with Eisner Safety Consultants or QuadTech, Incorporated. The web links to these organizations are provided for general information only. Organization logos are registered trademarks of the specific organization and are used with express permission from the specified organization.

The information presented here is subject to change and is intended for general information only

© Eisner Safety Consultants

Telephone: 1-503-244-6151, Website: <http://www.EisnerSafety.com>

Printed in U.S.A.

January 2002